

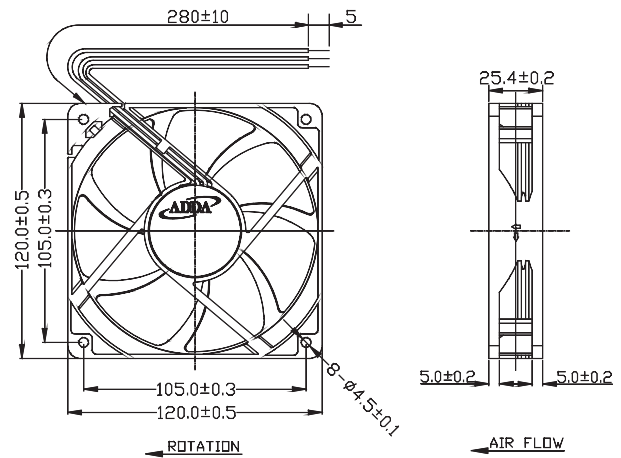

AG12025 SERIES

External Dimensions



Frame: Plastic(UL:94V-0)
 Impeller: Plastic(UL:94V-0)
 Lead wire: UL1007AWG24

Specifications(Nominal)

*Noise is measured at the distance of one (1) meter from the axis of intake.

Bearing type: ○=Ball ※=Sleeve ●=Hypro bearing

Frame size (mm)	Model No.	Bearing System Type	Rated Voltage (VDC)	Current (A)	Power (W)	Rated Speed (rpm)	Maximum AirFlow (CMM)	Maximum AirFlow (CFM)	Maximum Pressure (InAq)	Maximum Pressure (mmAq)	*Noise Level (dB/A)	Weight (g)
120x120x25	AG12012DB257B00	○ ※ ●	12	0.12	1.44	1900	1.631	57.662	0.124	3.149	31.10	185.0
	AG12012LB257B00	○ ※ ●	12	0.15	1.80	2200	1.896	67.015	0.169	4.292	34.60	
	AG12012MB257B00	○ ※ ●	12	0.21	2.52	2500	2.153	76.081	0.212	5.384	38.40	
	AG12012HB257B00	○ ※ ●	12	0.30	3.60	3100	2.679	94.689	0.310	7.874	44.80	
	AG12012UB257B00	○ ※ ●	12	0.48	5.76	3600	3.007	106.272	0.392	9.956	49.10	
	AG12012XB257B00	○ ※ ●	12	0.80	9.60	4100	3.478	122.921	0.480	12.192	52.00	
	AG12024DB257B00	○ ※ ●	24	0.07	1.68	1900	1.631	57.662	0.124	3.149	31.10	
	AG12024LB257B00	○ ※ ●	24	0.08	1.92	2200	1.896	67.015	0.169	4.292	34.60	
	AG12024MB257B00	○ ※ ●	24	0.11	2.64	2500	2.153	76.081	0.212	5.384	38.40	
	AG12024HB257B00	○ ※ ●	24	0.16	3.84	3100	2.679	94.689	0.310	7.874	44.80	
	AG12024UB257B00	○ ※ ●	24	0.25	6.00	3600	3.007	106.272	0.392	9.956	49.10	
	AG12024XB257B00	○ ※ ●	24	0.32	7.68	4100	3.478	122.921	0.480	12.192	52.00	
	AG12048LB257B00	○ ※ ●	48	0.05	2.40	2200	1.896	67.015	0.169	4.292	34.60	
	AG12048MB257B00	○ ※ ●	48	0.06	2.88	2500	2.153	76.081	0.212	5.384	38.40	
	AG12048HB257B00	○ ※ ●	48	0.11	5.28	3100	2.679	94.689	0.310	7.874	44.80	
	AG12048UB257B00	○ ※ ●	48	0.14	6.72	3600	3.007	106.272	0.392	9.956	49.10	

Specifications subject to change without notice.

The specification for bearing type is for reference only, for more bearing types information, please contact with your ADDA sales representative, thanks!!
 (網頁上呈現產品軸承資訊均以2Ball為主, 若需其他產品資訊請聯絡您在ADDA的業務代表, 謝謝!!)

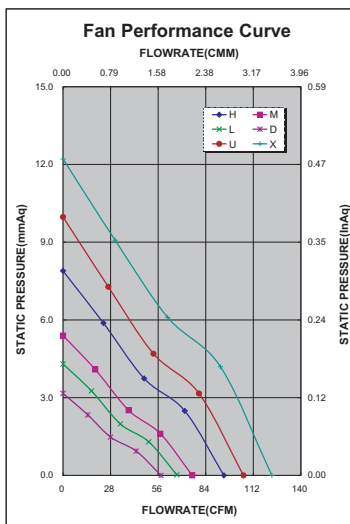

*Motor protective circuit and third lead wire functions

0	1	2	3	4	6	7	8	9	A	B
✓	✓	✓	✓		✓			✓		✓

*Safety approvals

✓	✓		✓	✓