

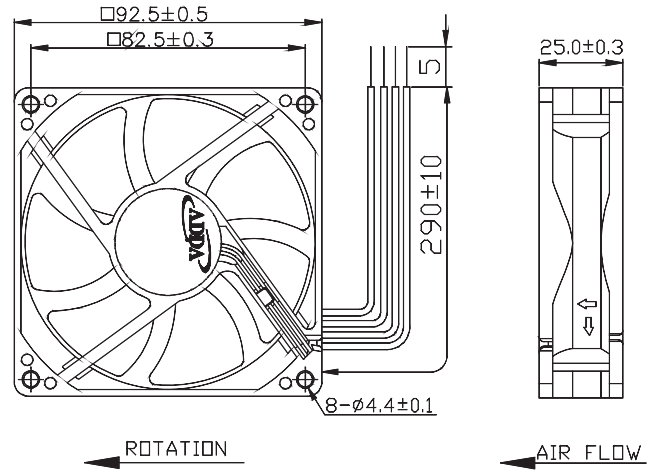

AD9225 3 PHASES SERIES



External Dimensions



Frame: Plastic(UL:94V-0)
 Impeller: Plastic(UL:94V-0)
 Lead wire: UL1061AWG26

Specifications(Nominal)

*:Noise is measured at the distance of one (1) meter from the axis of intake.

Bearing type: ⊙=Ball ※=Sleeve ●=Hypro bearing

Frame size (mm)	Model No.	Bearing System Type	Rated Voltage (VDC)	Current (A)	Power (W)	Rated Speed (rpm)	Maximum AirFlow (CMM) (CFM)	Maximum Pressure (InAq) (mmAq)	*Noise Level (dB/A)	Weight (g)
92x92x25	AD09212UB257BZ0	⊙	12	0.33	3.96	4000	1.965 69.368	0.311 7.910	47.0	100.0

Specifications subject to change without notice.

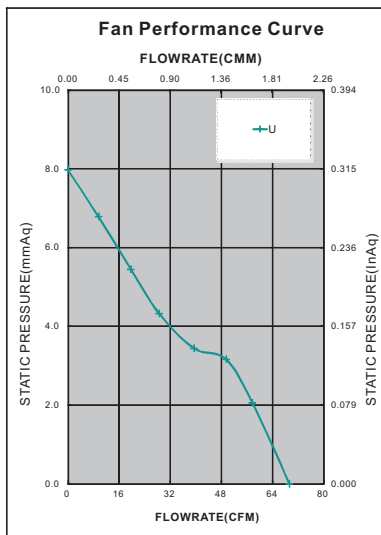

*Motor protective circuit and third lead wire functions

0	1	2	3	4	6	7	8	9	A	B
	✓		✓					✓		✓

*Safety approvals

				✓